

# Young Researchers Seminar 2009

Torino, Italy, 3 to 5 June 2009

---

## Geometric and Absolute Calibration of the English Highways Agency Traffic Speed Deflectometer

Michael Jenkins

---



# Table of Contents

- About TRL
- Current deflection measurement in the UK
- Traffic speed deflectometer (TSD)
- Geometric calibration
- Absolute calibration
- Conclusions

---

**Calibration of the Traffic Speed Deflectometer**

**Michael Jenkins**



# TRL



## Independent Transport Research, Consultancy & Testing

**Creating** the future of transport

**Calibration of the Traffic Speed Deflectometer**

**Michael Jenkins**



# Current Deflection Measurement in the UK

## Falling weight deflectometer (FWD)

- Point measurements
- High Precision
- Stationary reference frame



Calibration of the Traffic Speed Deflectometer

Michael Jenkins



# Current Deflection Measurement in the UK

## Deflectograph

- Automated point measurements
- 2.5 km/h
- Measurements every 3 - 4 m



Calibration of the Traffic Speed Deflectometer

Michael Jenkins



# Traffic Speed Deflectometer (TSD)



## Description

Possible survey speeds

10-80 km/h

Typical survey speed

70 km/h

Maximum temporal resolution (millisecond)

1 ms

Typical spacial resolution (after processing)

1 m

Maximum daily coverage

~ 500 km

Equipment operating temperature

20° C

## Calibration of the Traffic Speed Deflectometer

Michael Jenkins



# Traffic Speed Deflectometer (TSD)

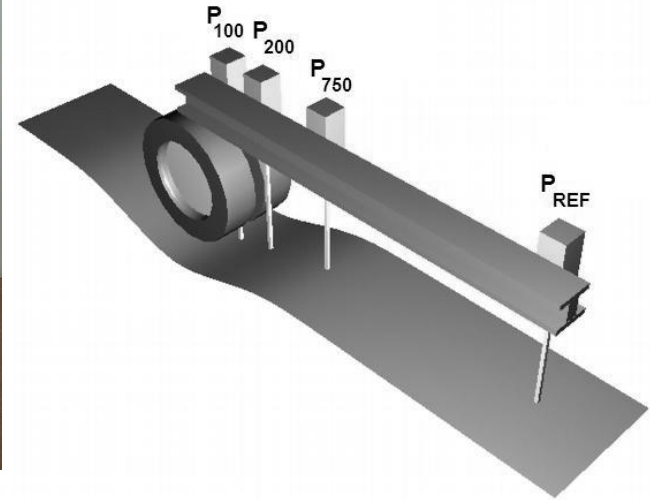
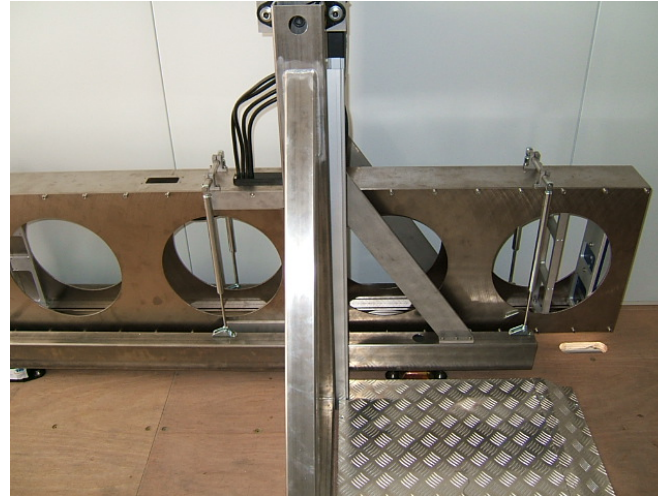

- Three measurement and one reference laser mounted on a stiff steel beam
- Lasers to measure the speed at which the pavement is deflected exploit the doppler principle
- Other beam sensors used to monitor motion of the beam

Calibration of the Traffic Speed Deflectometer

Michael Jenkins



# Traffic Speed Deflectometer (TSD)

$V_{\text{vehicle}}$  = TSD speed  
 $V_{\text{Deflection}}$  = true vertical deflection velocity

$$\text{Slope} = \frac{v_{\text{Deflection}}}{v_{\text{vehicle}}}$$

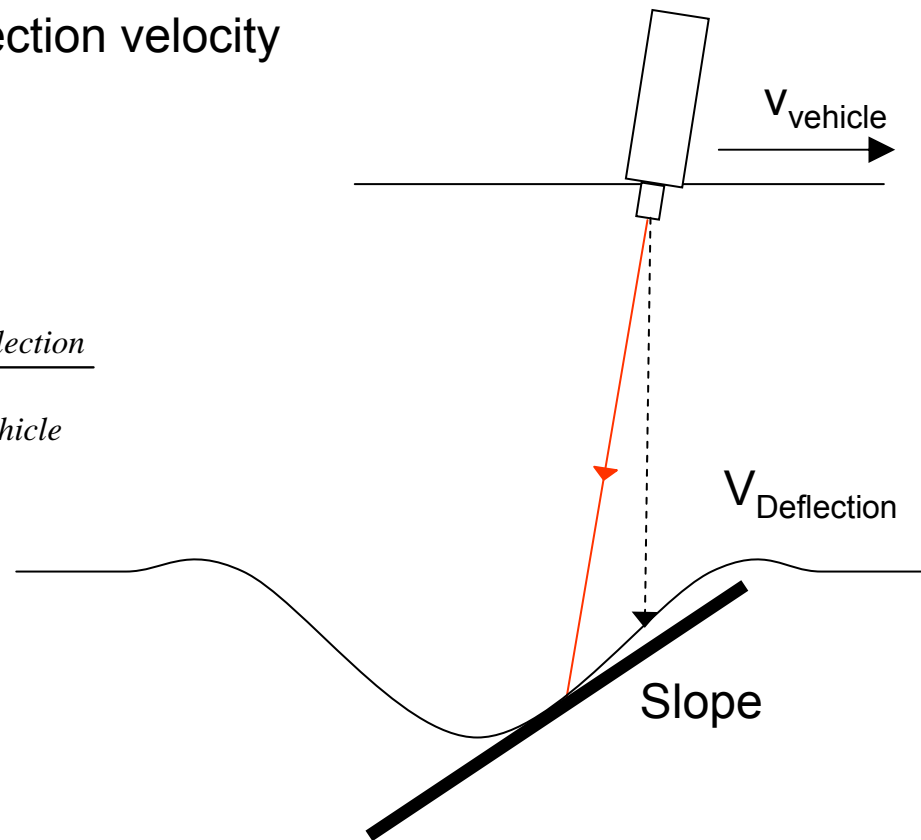

Calibration of the Traffic Speed Deflectometer

Michael Jenkins



# Traffic Speed Deflectometer (TSD)

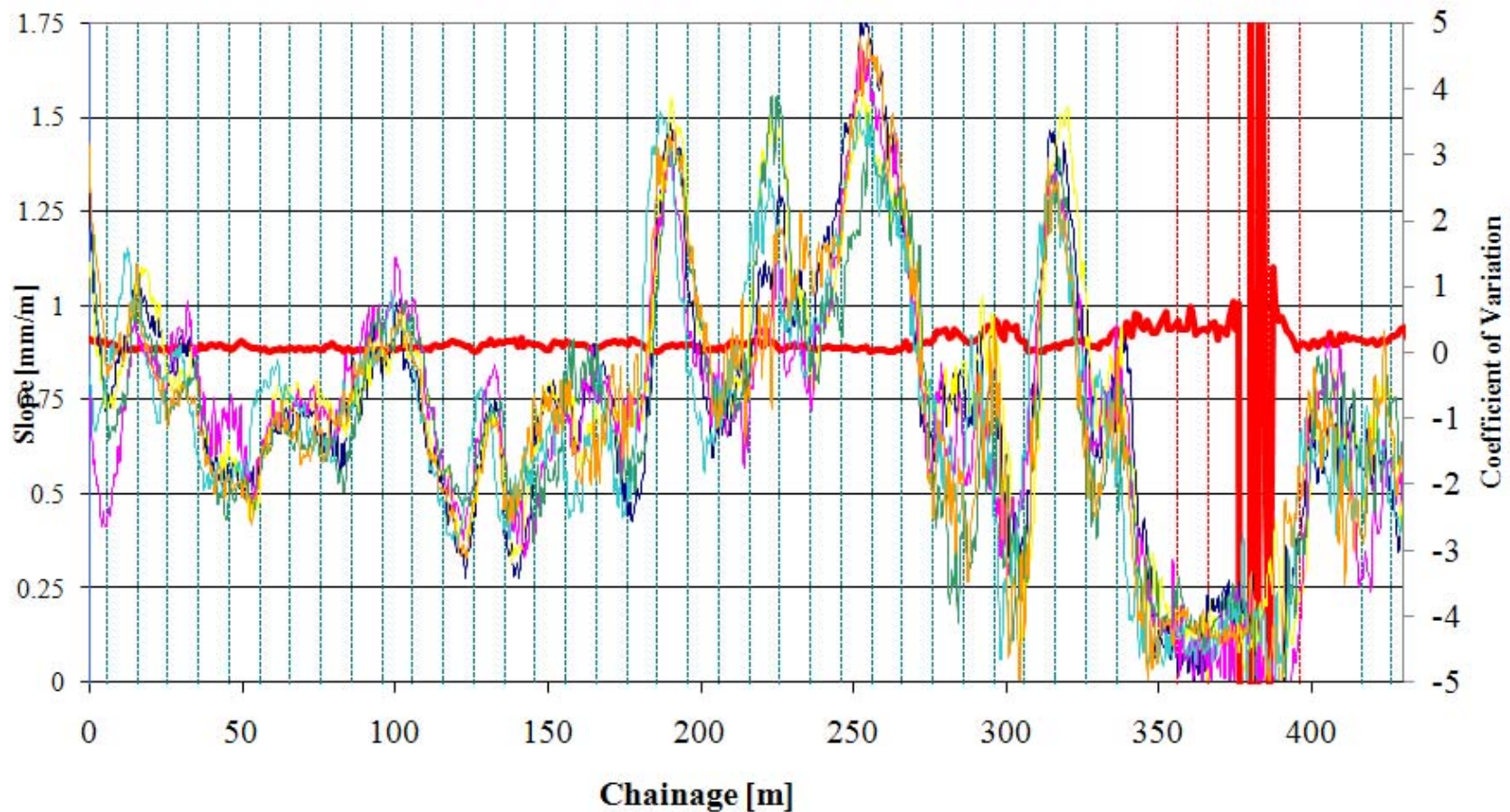

Calibration of the Traffic Speed Deflectometer

Michael Jenkins



# Geometric Calibration

Lasers mounted ~ 2 degrees from vertical which measures

- Horizontal vehicle velocity
- Vertical and horizontal suspension velocity
- Vertical pavement deflection

High precision required - error in angle of  $0.005^\circ$  could produce a 25% error.

It is impossible to mount the lasers at exactly 2 degrees from vertical so calibration is required to correct the differences between the angles of the lasers.

# Principles of Geometric Calibration

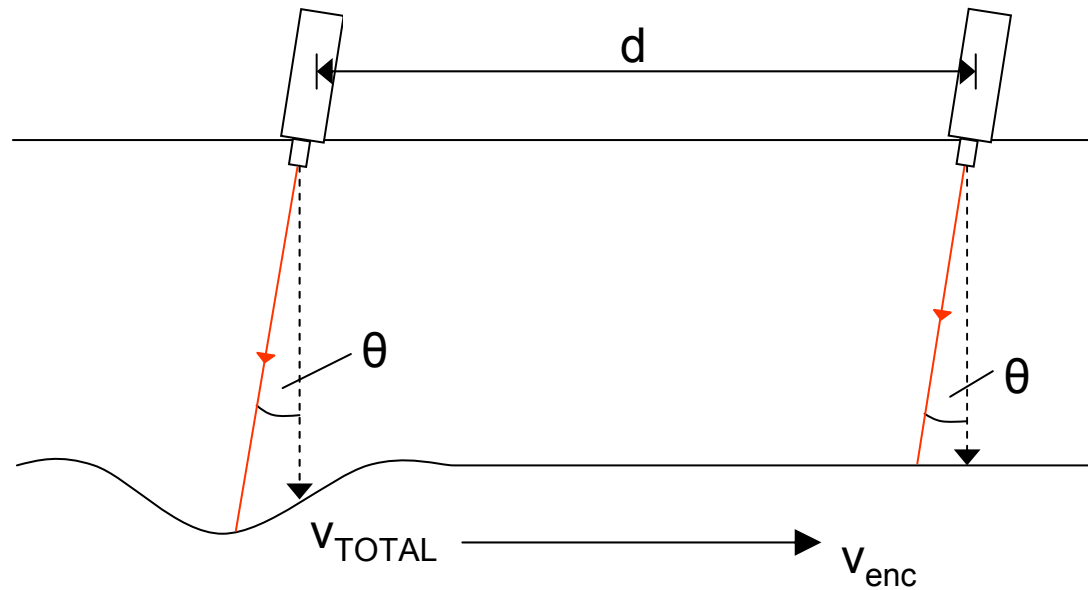

$$V_{TOTAL} = V_{VERT} \cos \theta + V_{HOR} \sin \theta$$

$$V_{TOTAL} = V_{VERT} + V_{HOR} \sin \theta$$

$$\sin \theta = \frac{V_{TOTAL} - V_{VERT}}{V_{HOR}}$$

Calibration of the Traffic Speed Deflectometer

Michael Jenkins



# Manufacturer Geometric Calibration

## Manufacturer Calibration Method

- Removal of 5 tonne ballast
- Running TSD over stiff concrete, assumed to have no deflection  
i.e.  $V_{VERT} = 0$
- Calculate laser angles from assumed zero slopes



$$\sin \theta = \frac{V_{TOTAL} + V_{VERT}}{V_{HOR}}$$

## Issues

- Assumption that no deflection occurs
- Negative slopes occur if stiffer concrete is tested
- Calibration concrete may deteriorate for subsequent calibrations

Calibration of the Traffic Speed Deflectometer

Michael Jenkins



# TRL Geometric Calibration (Dynamic)

Measure  $V_{\text{VERT}}$  using an accelerometer



Calibration of the Traffic Speed Deflectometer

Michael Jenkins



# TRL Geometric Calibration (Dynamic)

Responses compared to known impact from FWD

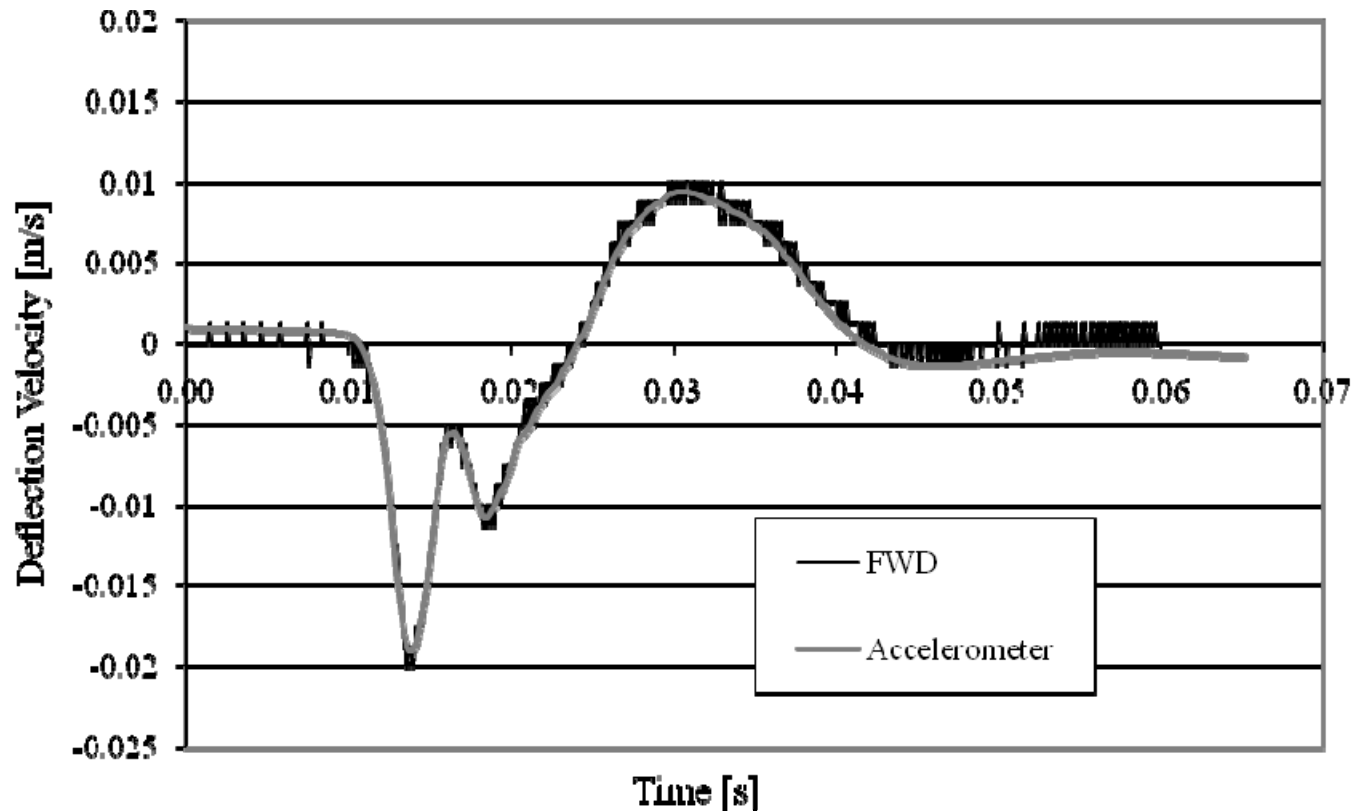

Calibration of the Traffic Speed Deflectometer

Michael Jenkins



# TRL Geometric Calibration (Dynamic)

Accelerometer response from TSD pass on concrete and asphalt

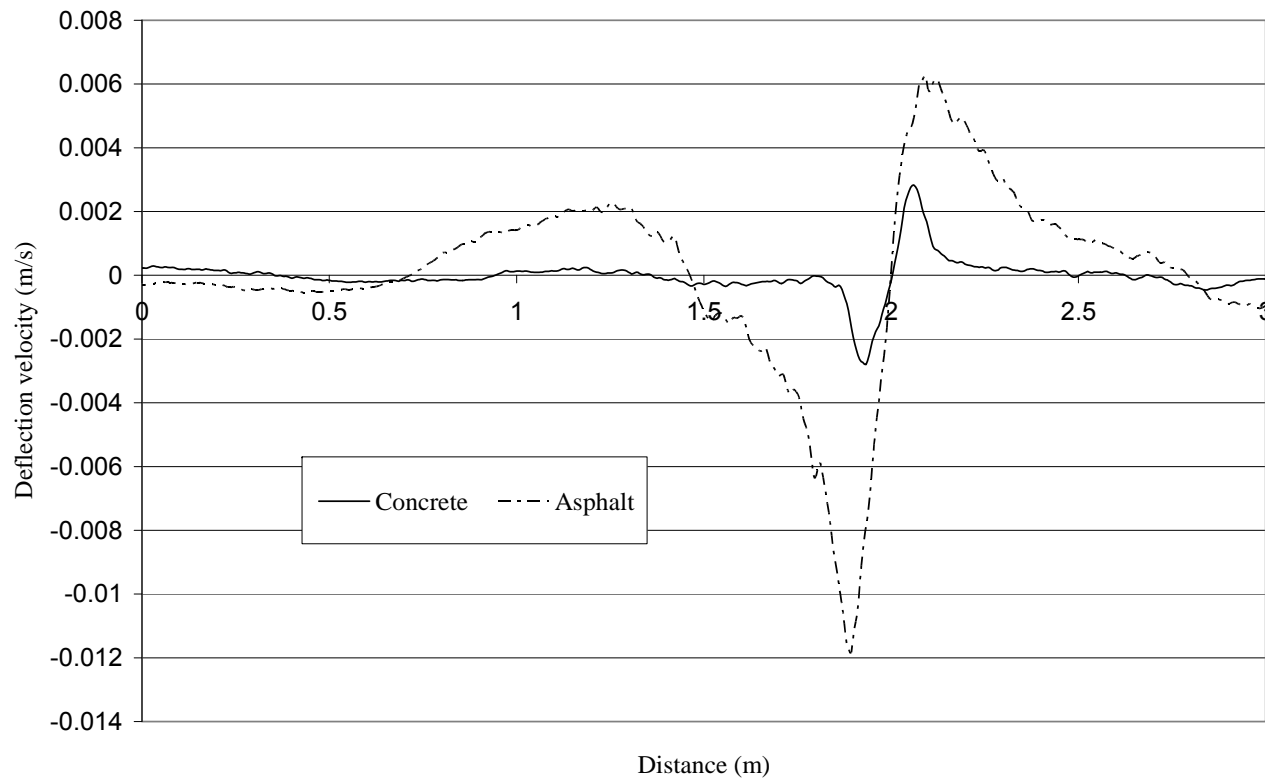

Calibration of the Traffic Speed Deflectometer

Michael Jenkins



# TRL Geometric Calibration (Dynamic)

## Calibration Procedure

- Run TSD over structurally sound pavement with uniform deflection
- Deflection velocities from the four lasers are integrated to produce distances, which are dependent on
  - Horizontal distance of TSD
  - Deflection velocity of pavement under load
  - Laser angle

Horizontal distance and deflection velocity are known, laser angles can be calculated.

$$\sin \theta = \frac{V_{TOTAL} + V_{VERT}}{V_{HOR}}$$

Where  $V_{VERT} = V_{ACC}$

# Absolute Calibration

## Directly Relating TSD to Pavement Performance

Geometric calibration enables collection of accurate deflection velocity and slope data

Allows comparison to equivalent values produced by the FWD and DFG and uses original relationships to estimate pavement residual life

- Not best use of TSD data
- Unnecessary intermediary stage

Absolute calibration will enable TSD slope data to be directly related to structural strength and residual life of pavements.

- Improve confidence limits
- Provide greater assurance in the estimates of the TSD

# Conclusion

The TSD offers the possibility of delivering structural surveys at traffic speed.

The work TRL has done on a geometrical calibration has shown that the TSD can deliver consistent results. The comparison to the Deflectograph has demonstrated that the TSD can be related to a measure of road deterioration.

This relationship will be developed and used as TRL's calibration method before the data necessary to derive an absolute relationship between TSD deflection slope and road condition has been collected.

Thank You.

Any questions or comments?

---

**Calibration of the Traffic Speed Deflectometer**

**Michael Jenkins**



# Title

---

**Calibration of the Traffic Speed Deflectometer**

**Michael Jenkins**

